

FLEXI-FRAME DISPLAY UNIT - INSTALLATION GUIDELINES (Parts & Accessories)

Flexi-Frame Assembly

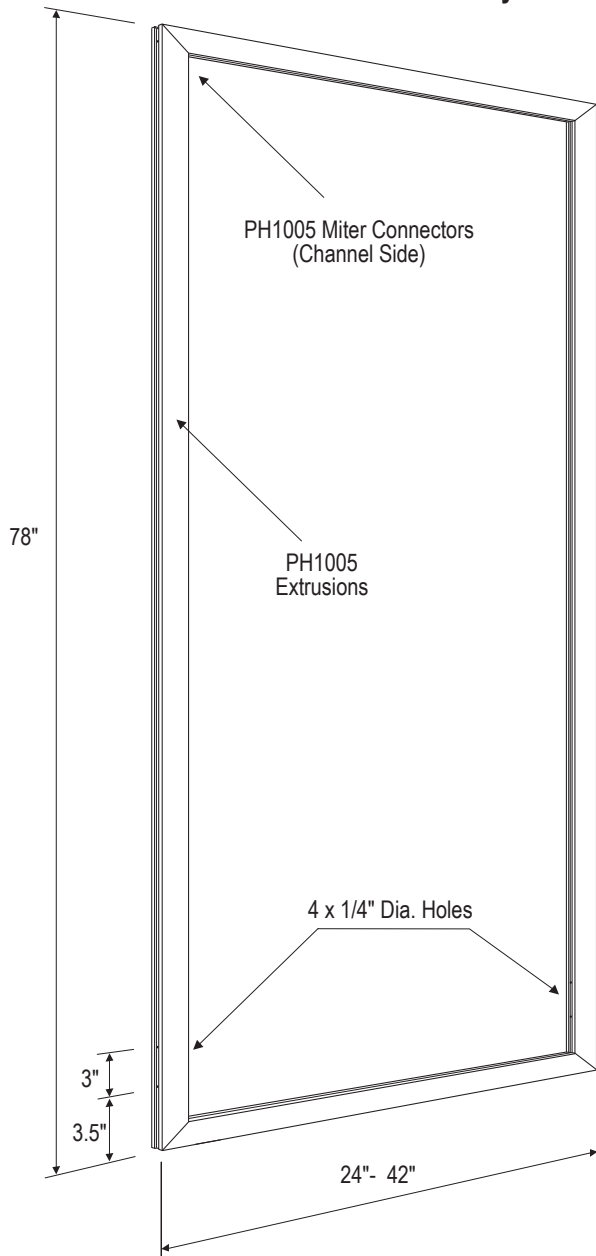

1.

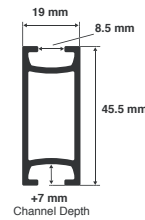

PH 1005
Ref. 104

Lengths: 24" - 42"
Finish: Clear anodized

2.

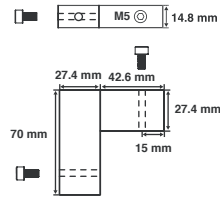
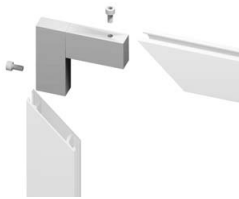

Miter Connector
Ref. 223 01

PH 1005 Miter (Channel Side)

For Use With: PH 1005

Includes: Two screws Ref. DIN912
M5 x 10"

Drilling Info: Requires drilling of extrusion

● Hex Key: 4 mm ⚖ Weight: 0.29lbs

3.

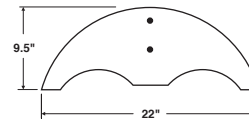
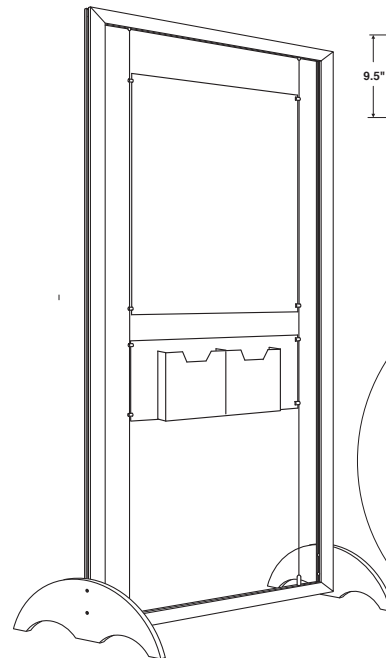

Acrylic Leg-Support
Ref. 12LEG

PH 1005 Miter (Channel Side)

For Use With: PH 1005

Includes: Two mounting screws*

Drilling Info: Requires drilling of extrusion

⚖ Weight: 3.46lbs

CORNER DETAIL

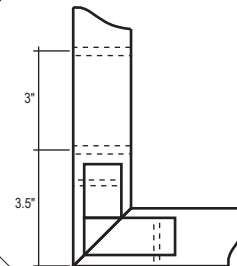

CABLE ASSEMBLY

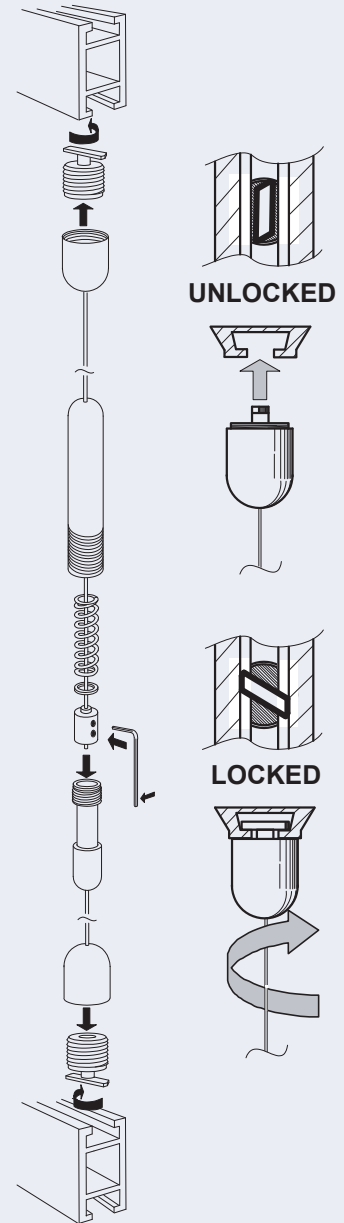

FLEXI-FRAME DISPLAY UNIT - INSTALLATION GUIDELINES (Parts & Accessories)

Flexi-Frame Assembly

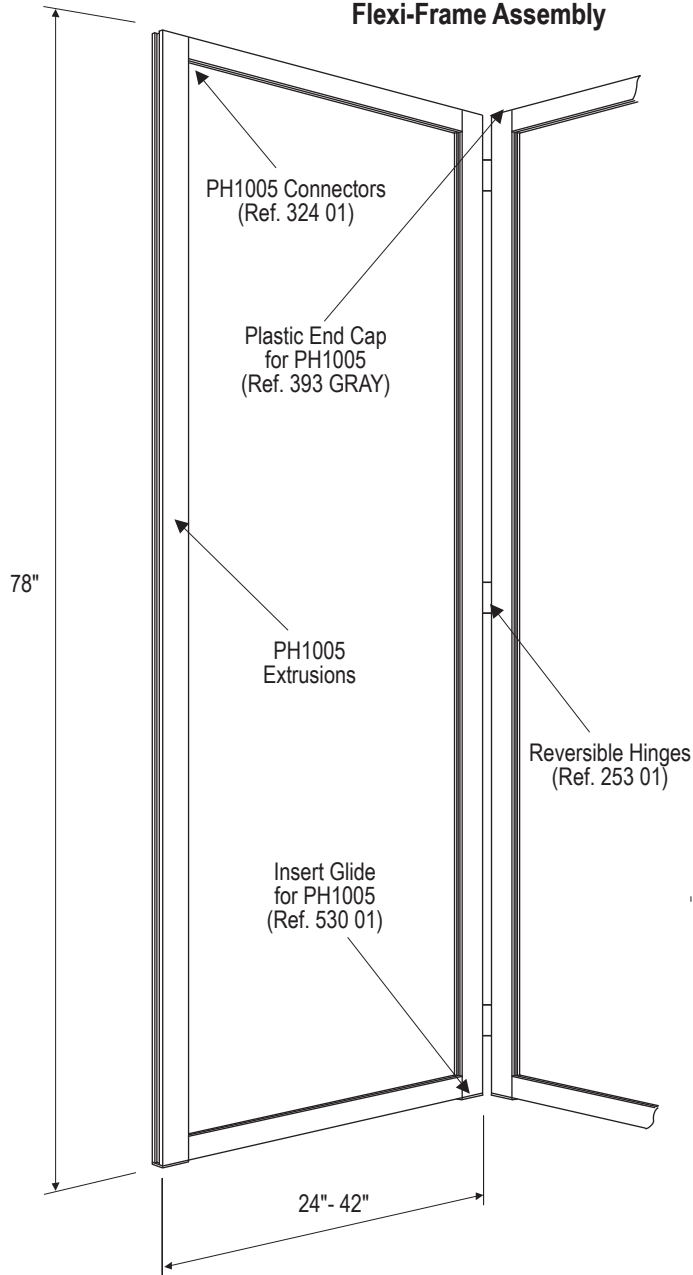

1.

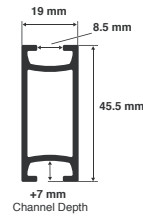

PH 1005
Ref. 104

Lengths: 24" - 42"
Finish: Clear anodized

2.

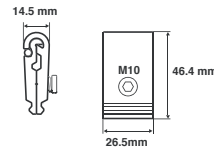

CBX 42
Ref. 324 01

CBX 42 with Screw
For Use With: PH 1005

● Hex Key: 5 mm ▲ Weight: 0.08lbs

3.

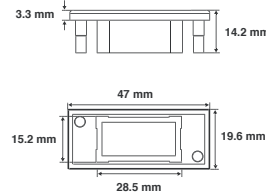
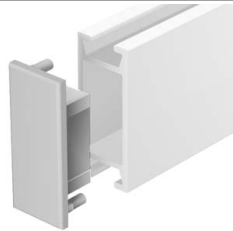

End Cap
Ref. 393

Plastic End Cap
For Use With: PH 1005
Colors: Gray / Black / White

▲ Weight: 0.01lbs

4.

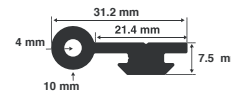

Hinge Ext. (Sm.)
Ref. 157

Lengths: Up to 120 in. (3048 mm)
Finish: Clear anodized

5.

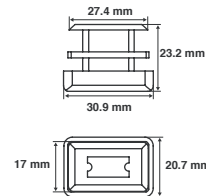

Insert Glide
Ref. 530 01

Insert Glide
For Use With: PH 1005
Material: Glide made of black plastic
(Used for floor protection)

▲ Weight: 0.01lbs

CABLE ASSEMBLY

